

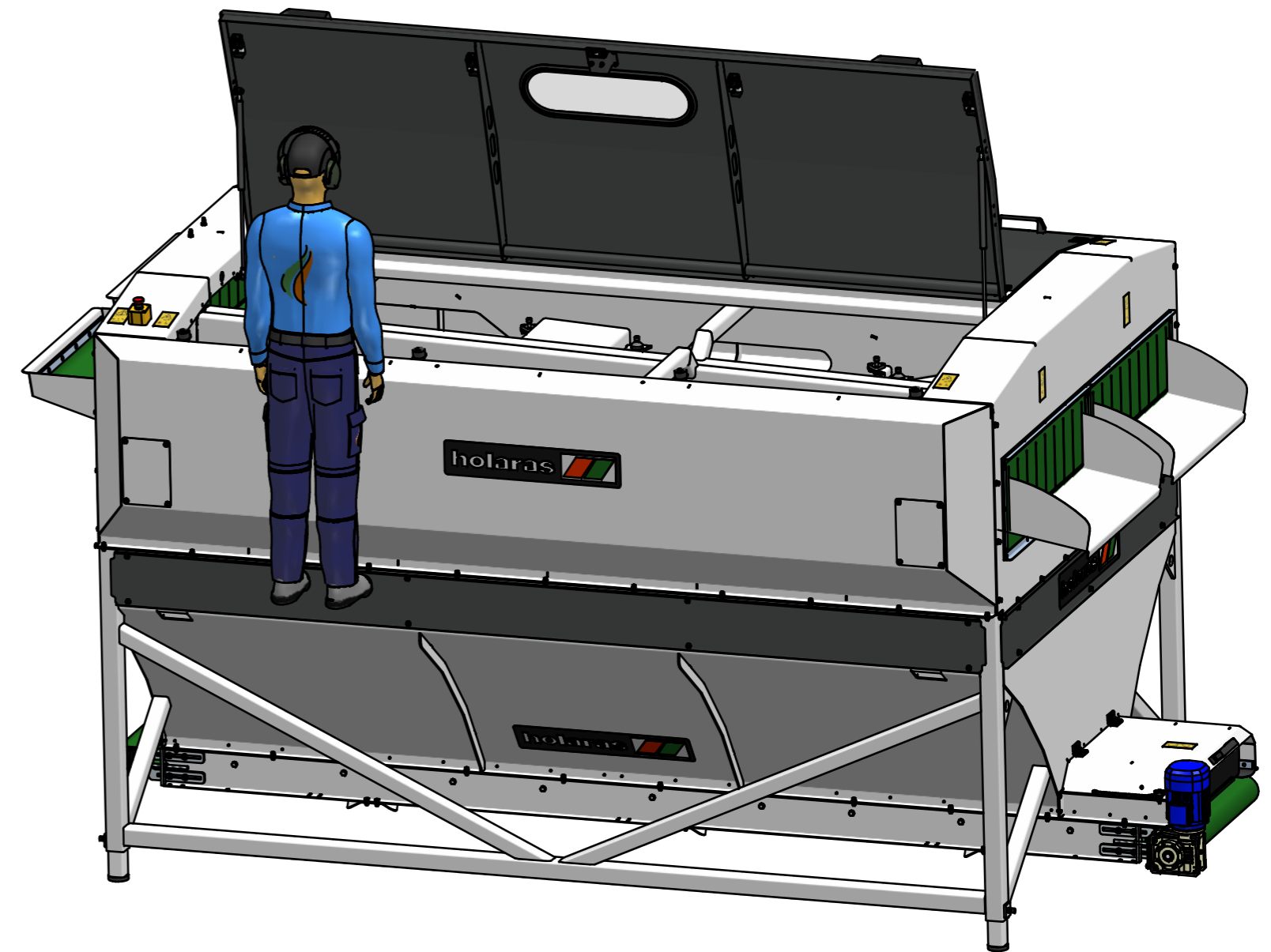

Turn the machine 1-2 degrees forward for a optimal flow and rotation of the onions.

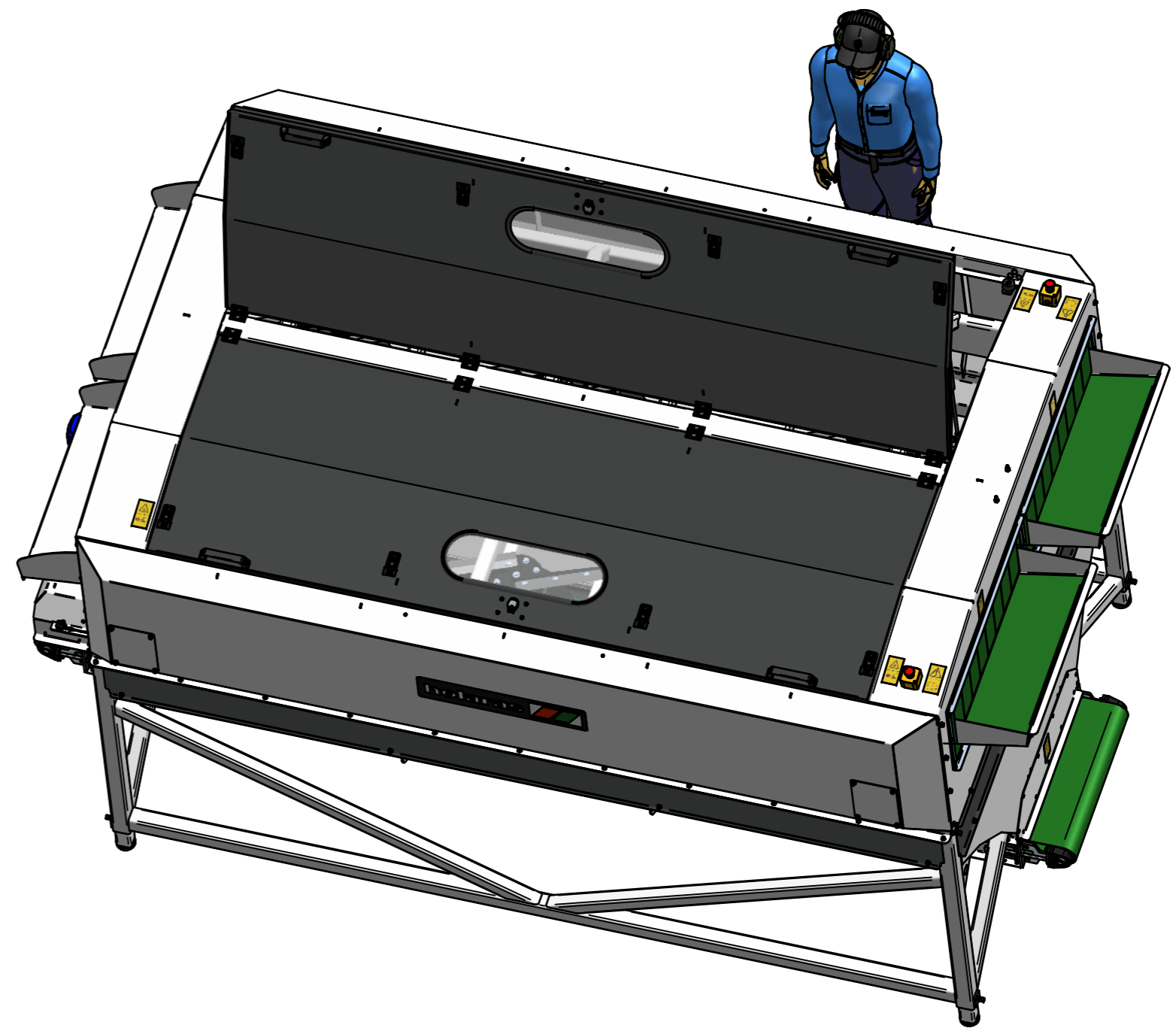
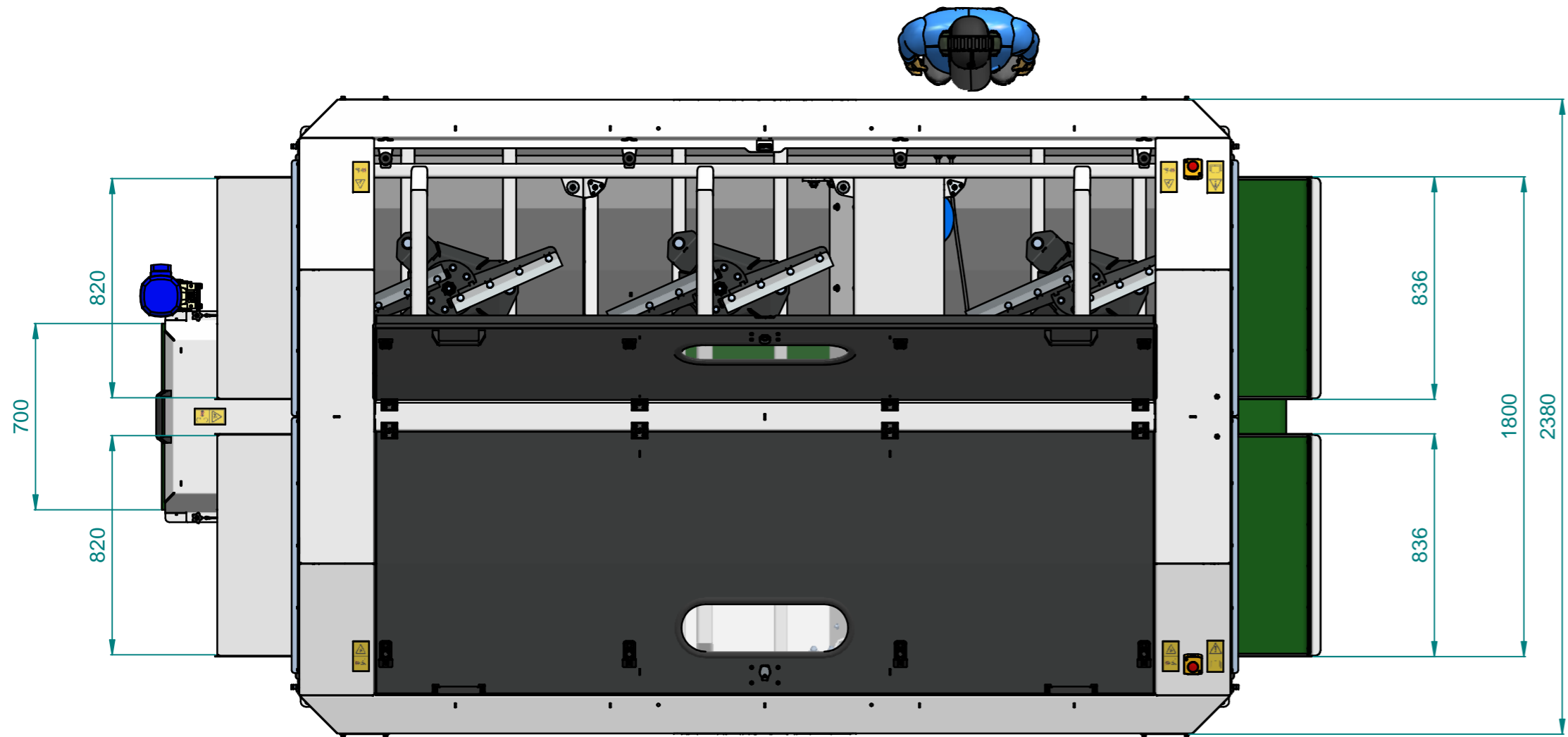
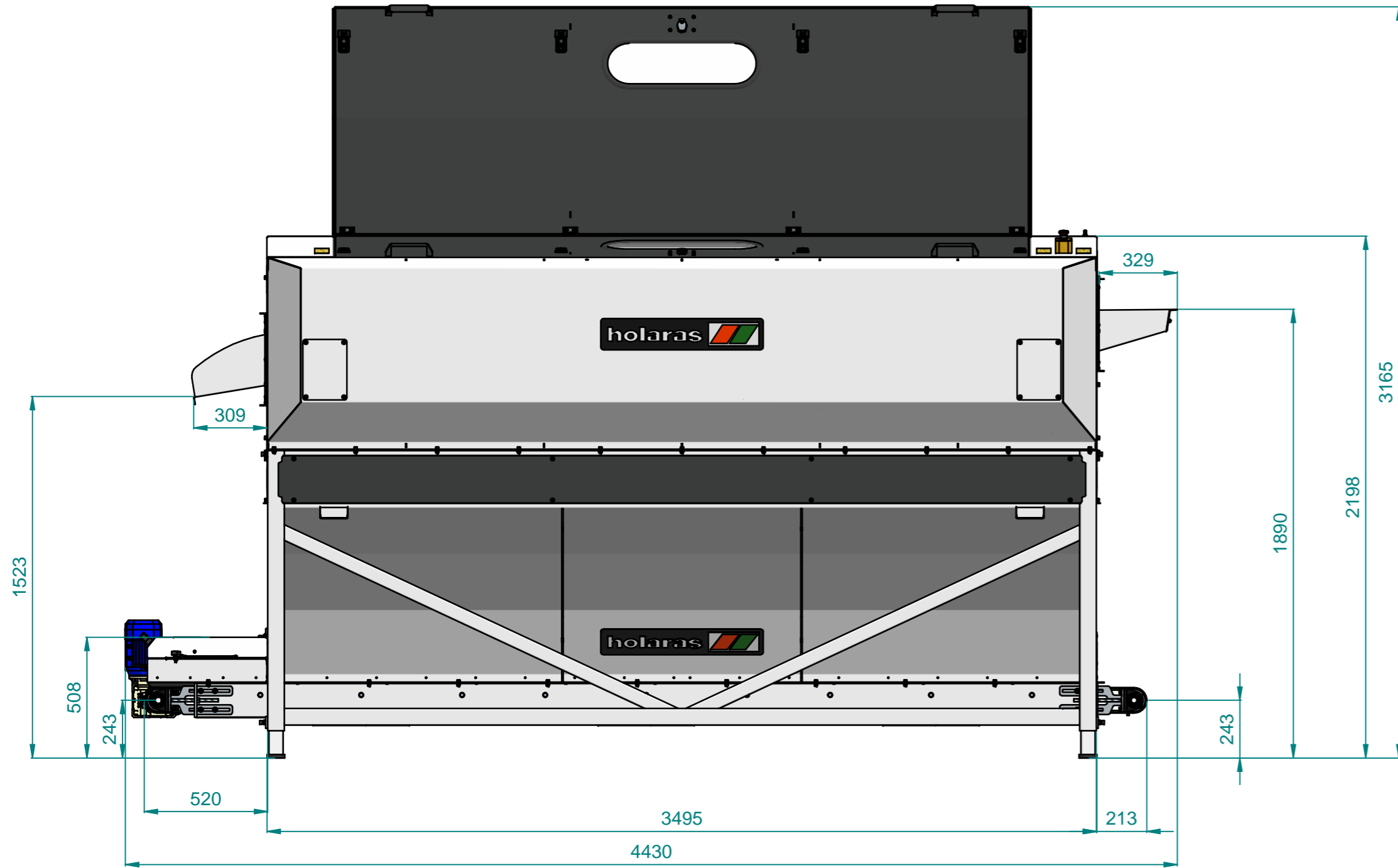
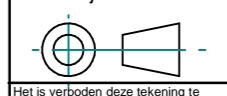

 Machinefabriek Holanda B.V. Dinxperlosestraatweg 145 NL - 7122 JP Aalten Tel.: +31(0)543-466224 Fax: +31(0)543-466464 @ : info@holaras.nl www.holaras.nl		Indien niet anders aangegeven Alg. tolerantie volgens ISO 2768-mk Them. doorsnijping volgens ISO 8013-2 Lasconstructies volgens ISO 13920-BE Hoeken zonder bemating zijn 90°		Benaming Afstaarter AS25	
		Am. Proj.  Datum 11-6-2021		Materiaal: B x H: 0x0 Lengte: 0 Diameter: ø0 Wanddikte: 0	
Get. LKE	Contr.	Tek. nr. 08A501	Pos. 00A	Rev.	Aantal Form. A2