

021670 Leafspring green

11 x 3 = 33

4 x 2 = 8

41 . 2 = 82

PRODUCT SPECIFICATIONS

PRODUCT: Pommes Frites

CONDITION: Frisch

SIZE: 7x7 bis 15x15

BULK DENSITY: 500 kg/m³

CAPACITY: 7000 kg/hr Max

Auch produkt mit Schale

CLEARANCES

A 35mm MINIMUM CLEARANCE MUST BE MAINTAINED BETWEEN MATING EQUIPMENT AND SHAKER. ENSURE MOTOR ROTATION IS CORRECT.

NO RIGID CONNECTIONS

TO BED, FRAME, OR ANY SHAKER COMPONENT IS ALLOWED. ALL COMPONENTS MUST BE ALLOWED TO MOVE FREELY DURING MACHINE OPERATION.

STATIC AND DYNAMIC LOADING

STATIC COMPONENT PER SUPPORT LOCATION (kg)	VERT	INFED DISCHARGE	
		182	146
DYNAMIC COMPONENT PER SUPPORT LOCATION (kg)			
SHUT DOWN - 200 TO 300 RPM	VERT	146	117
	HORIZ	127	102
OPERATING - DESIGN SPEED	VERT	55	44
	HORIZ	46	37

NOTES: 1) LOAD LOCATION IS AT TOP OF SUPPORT.
2) TOTAL LOAD IS THE SUM OF THE STATIC AND DYNAMIC COMPONENTS AT THE GIVEN CONDITIONS.

DESIGN SPEED : 970 rpm

DESIGN STROKE : 13 mm

MAX STROKE IS DESIGN STROKE + 1mm

SHAKER WEIGHT : 656 kg

TOTAL WEIGHT : 806 kg

BED WEIGHT : 178 kg

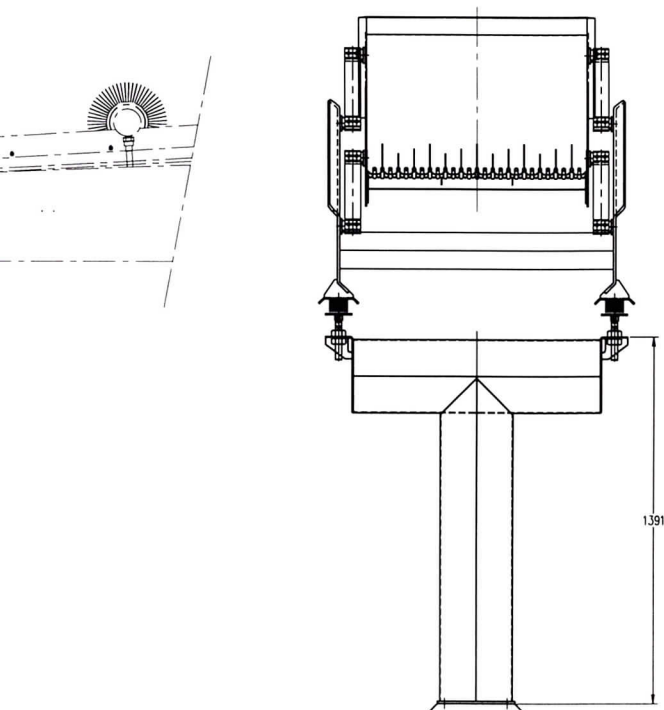

102.0547

QTY	16	021251	SHM LEAFSPRING	KEY		
8	021677	LEAFSPRING GREEN	KEY			l=270
1	021722	VARIABLE PITCH SHEAVE	ELECTRON	TYPE: 2 NR: 1VPS0		Ø120 x Ø24H7/Key
1	300202	BELT GUARD	SS 304			
1	410712-1	BELT GUARD	PLASTIC			
1	408643-3	WEIGHT GUARD MONDS	PLASTIC			
1	408643-2	WEIGHT GUARD DS LH	PLASTIC			
1	021662	BELT	A-44			
1	021913	BUSHING	1801 x 7/8"			
1	021912	SHEAVE	"A" Ø140mm			
1	022002	MOTOR 1.1kW	KWDM 90 S Ø78 R3 SS			230-400V/50Hz/50m
4	010618	DRIVE WEIGHT	SS	Ø72-18		
22	021994	ISO-DRIVE	SS	LARGE CASE LH		
21	016212	SWITCH OFF (FR)				
20	016265	HAMMS CLEAR (FR)				
19	009650	ROTATION (FR)				
18						
17	023392	TAG	KEY	ISO Ø10		
16	300127	STROKE INDICATOR		FROM 2-20		
15	023441	STROKE LABEL 13mm				
14	021263	EARTH STRAP	COPPER	l=325		TWO MOUNTING EYES
13						
12	6	300066.24	SPRINGEL Z GREEN 22.5L			SPRINGEL-6222-SS-3V-LH
11	6	300066.24	SPRINGEL Z GREEN 22.5L			SPRINGEL-6222-SS-3V-LH
10	9	300066.13	SPRINGEL Z GREEN 22.5L			SPRINGEL-6222-SS-2V-LH
9	9	300066.12	SPRINGEL Z GREEN 22.5L			SPRINGEL-6222-SS-2V-LH
8	4	300013.4	SHM #75	RVS 304	HOLE Ø14 mm	
7	4	300011	ADJ.BUFF.SUPP. #12	RVS 304		VOOR BUFFER #75
6	4	4	021648	ISOLATOR	RUBB	Ø75x55 SS DISC #12 TYPE B 40SHORE
5	1			SUPPORT INFED	SS 304	SHEET 05
4	1			SUPPORT DISCHARGE	SS 304	SHEET 04
3	1			DRIVE FRAME	SS 304	SHEET 03
2	1			DISCHARGE SECTION	SS 304	SHEET 02
1	1			BED	SS 304	SHEET 01

DATE: 01-05-06
SCALE: 1:10
DRAWN: v. Riessen
MACHINE CODE: MVAL/4100/8.4

CLIENT: Frigemo / Cressier, Schweiz
PROJECT: ADR4 INFED
Pos 18
SM 420925e

KEY

153431

00

AO