

# DEIMPILATORE PEDANE DAP-108



## **DEIMPILATORE PEDANE mod. DAP-108**

Il DAP-108 è un Deimpilatore Alimentatore di pedane di diversi formati, adatto ad alimentare pedane vuote impilate a qualsiasi palettizzatore Sorma.

Il DAP-108 viene alimentato da carrelli elevatori, che caricano fino a 8-10 pedane per ogni vano di carico (i vani possono essere al massimo 4), a seconda del formato (pedana da 800 o 1000 o 1200).

## **PALLET DESTACKER mod. DAP-108**

The machine mod. DAP-108 is a Destacker - Feeder for pallets of different sizes, suitable to feed empty stacked pallets to any Sorma palletiser.

The DAP-108 is fed by lifting trolleys that load up to 8-10 pallets for each loading compartment (the compartments can be a maximum of 4), depending on the size (pallets of 800 or 1000 or 1200).

## **DESEMPILEUR - ALIMENTATEUR mod. DAP-108**

La machine mod. DAP-108 est un Désempileur - Alimentateur de palettes de différents formats; elle permet d'alimenter de palettes empilées vides à n'importe quel palettiseur Sorma.

La DAP-108 alimente les chariots élévateurs, qui chargent jusqu'à 8 à 10 palettes pour chaque pièce de chargement (les pièces peuvent être au maximum 4), suivant le format (palettes de 800 ou 1000 ou 1200).

## DATI TECNICI/TECHNICAL DATA

POTENZA ELETTRICA INSTALLATA  
INSTALLED POWER  
PUISSANCE ELECTRIQUE INSTALLÉE  
ANSCHLUSSWERT ELEKTR  
POTENCIA ELÉCTRICA INSTALADA  
Установленная мощность

1,5 kW • 50 Hz • 400 V

CONSUMO ARIA  
AIR CONSUMPTION  
CONSOMMATION D'AIR  
LUFTVERBRAUCH  
CONSUMO DE AIRE  
Потребление воздуха

5 NI/min • 6 bar

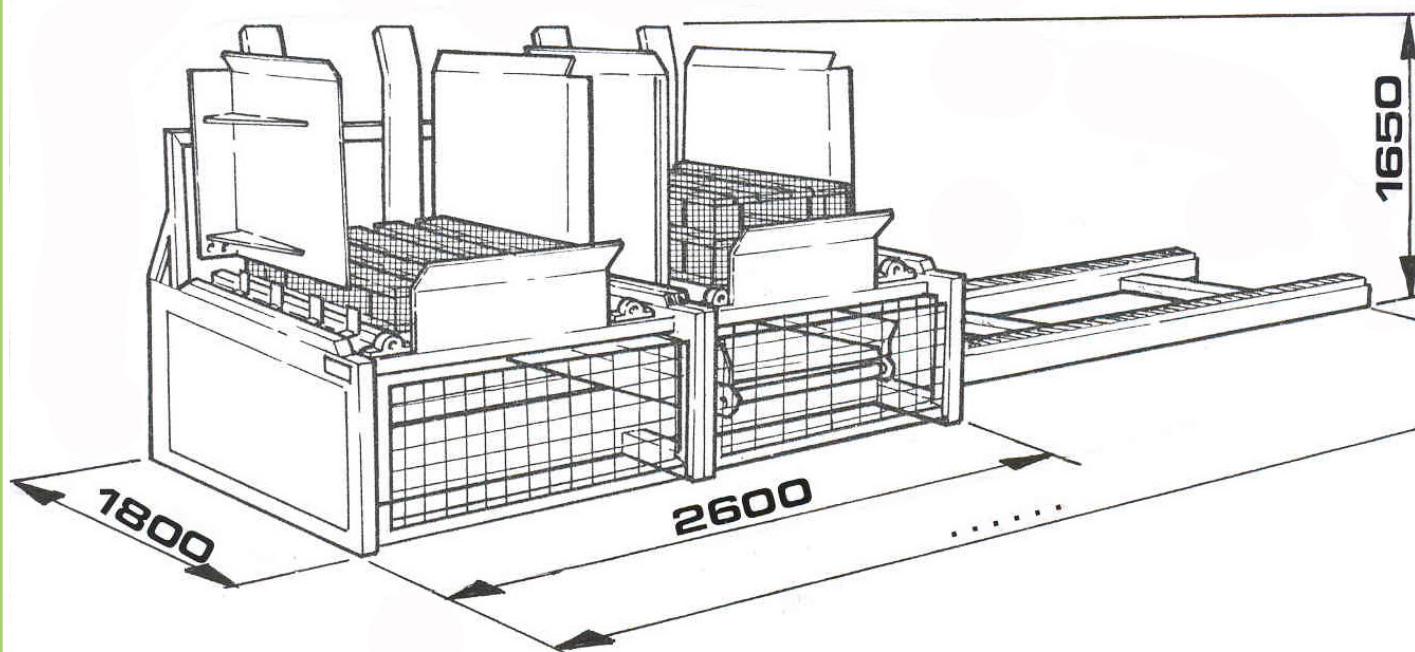

## DEIMPILATORE PEDANE DAP-108

AGENTE DI ZONA / LOCAL DEALER



**SORMA S.p.A.**

via Delle Mele, 65 - 47522 Cesena (FC) - ITALY  
Tel. (+39) 0547 418611 - Fax. (+39) 0547 418612  
sorma@sormaitalia.com - www.sormagroup.com